

TECHNICAL SPECIFICATIONS

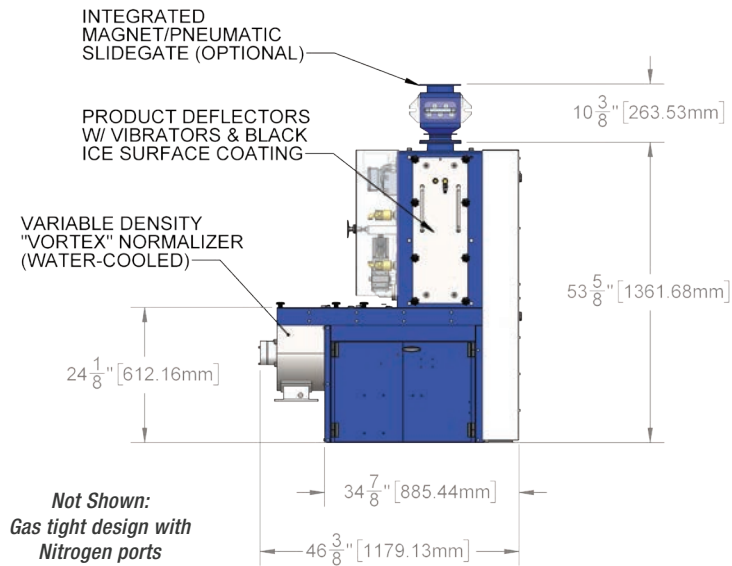

600.MM.2 Two Stage Grinding System



600.MM.3 Three Stage Grinding System

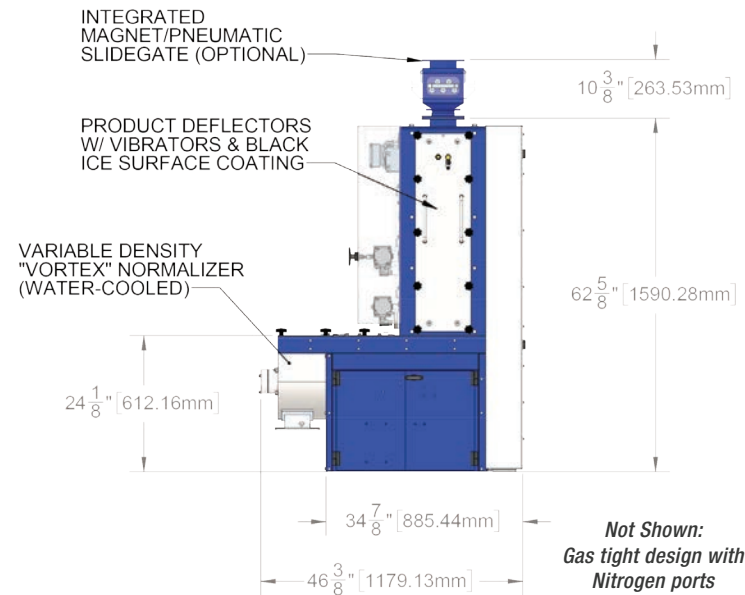

ACCOMMODATES ALL SINGLE SERVE GRIND SIZES	SPECIFICATIONS	MINI.MAX MODEL 600.MM.2	MINI.MAX MODEL 600.MM.3
	Roll Size:	6 x 8 inches [152 x 200 mm]	6 x 8 inches [152 x 200 mm]
	Sections:	Two (2) stacked grinding sections	Three (3) stacked grinding sections
	Power:	Mixer: 5.4 hp [4 kw] 60 hz Grinder: 7.5 hp [5.7 kw] 60 hz	Mixer: 5.4 hp [4 kw] 60 hz Grinder: 7.5 hp [5.7 kw] 60 hz
	Capacity & Density*:	160 kg/hr @ 0.370 g/cc 320 kg/hr @ 0.340 g/cc	160 kg/hr @ 0.370 g/cc 320 kg/hr @ 0.340 g/cc

*Nespresso™ compatible capsules

AUTOMATED PLC CONTROL SYSTEM

Menu driven system controls every facet of the grinder to achieve:

- Separate recipes for each product, optimizing every coffee specification
- Operational Coordination with Packaging Machine
- Coffee Granulometry (Grind)
- Coffee Temperature
- Coffee Density (Compaction)
- Essentially everything

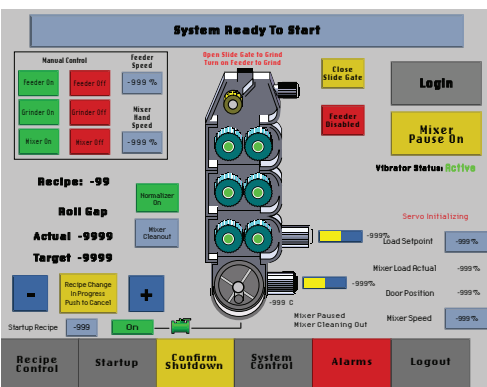

© 2020 Modern Process Equipment Corporation

MODEL 600.MM MINI.MAX™ SERIES ROLLER-STYLE CAPSULE GRINDERS

Minimum Size. Maximum Performance.



*Picture is representative of the size.

MODEL 600.MM

The Mini.Max is the world's most powerful, precision, capsule grinder. The uniformity and consistency of both grind profile and density are assured with the MPE Mini.Max.



A REVOLUTIONARY GRINDER FOR THE COFFEE INDUSTRY

Size Matters. Kilo for kilo, pound for pound, the Mini.Max is the most powerful capsule grinder ever built.

The compact Mini.Max can be configured in your process as either a "Stand-Alone" system or as a "Sit on Top" grinder at your capsule packaging machine. This provides the "twin" requirements of both ideal grind distribution and densification.

THE MODEL 600.MM MINI.MAX SERIES CAPSULE GRINDER PROVIDES:

- 1 The highest quality roller-style capsule grind allows for higher extraction yields and consistent flow times.
- 2 The most versatile density control provides higher densification capabilities to improve gram weight control and increase coffee brew strength.
- 3 Full range grind capability from 200 to 800 microns.

THE PERFECT ADDITION

The Model 600.MM Mini.Max series roller-style capsule granulizer fits into any plant design to provide your capsule packaging equipment with the perfect grind, where you need it, when you need it.

COMPARE THE DIFFERENCE

	DISC-STYLE GRINDERS	MINI.MAX
Roller-Style Grinding Integrity	✗	✓
True Low Temperature Water Cooled	✗	✓
Absolute Density Control (Patented)	✗	✓
Grind Distribution Meets Highest End-User Acceptance	✗	✓
Compact, Can Sit On Top Of Packaging Machine	✓	✓

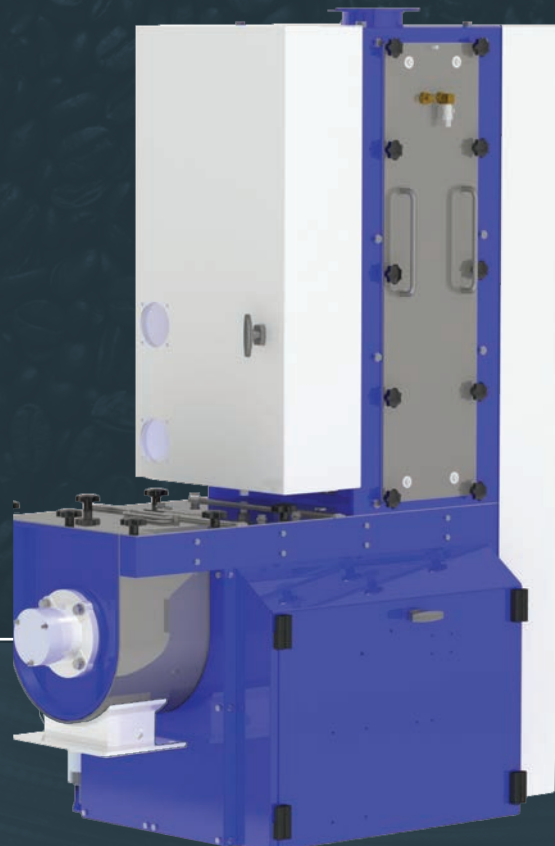

THE PERFECT GRIND

Now, the quality grind that was previously only achieved with a roller-style grinder can be installed, economically, in tandem with capsule filling machines. It is no longer necessary to compromise quality with a disc-style grinder.

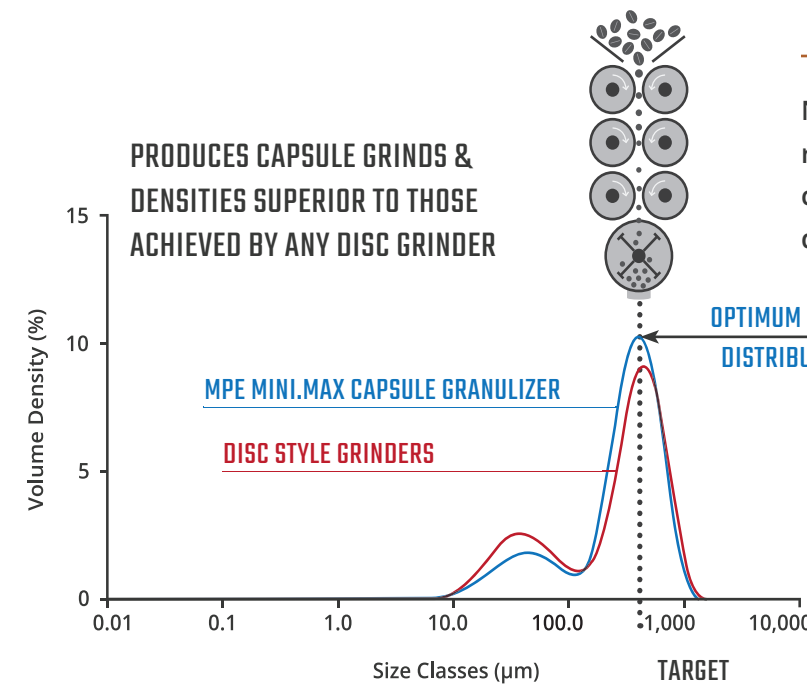

DUAL CONFIGURATION OPTIONS

1 TANDEM GRINDING CONFIGURATION

The 600.MM.3 grinder can operate in a "Stand-Alone" system.

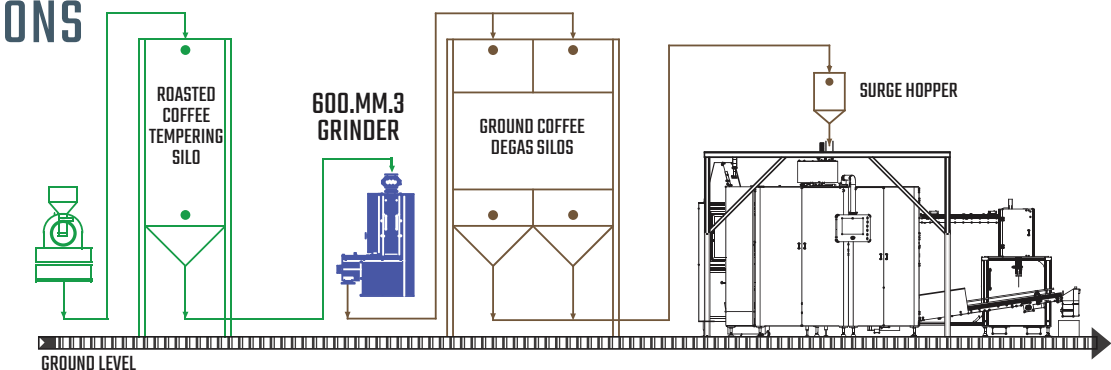

2 GRINDING IN PLACE CONFIGURATION

The 600.MM.2 grinder can "Sit on Top" of the Packaging Machine.

