

MODERN PROCESS EQUIPMENT CORPORATION

**CHAIN-VEY®**



**THE  
BETTER  
WAY TO CONVEY  
PET FOOD**



**www.CHAINVEY.com**

+1.773.254.3929 • SOLUTION@CHAINVEY.COM





# THE MOST GENTLE & EFFICIENT TRANSPORT AVAILABLE FOR PET FOOD APPLICATIONS

## CHAIN-VEY CONFIGURATION WITH MULTIPLE INLETS AND DISCHARGE(S) UP TO 250 FT. AWAY

### ROTARY DISCHARGE VALVE

Pneumatically actuated rotary valve allows for unobstructed product discharge

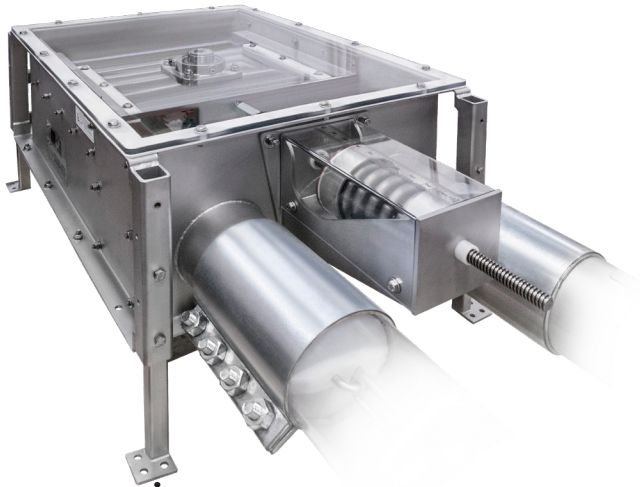
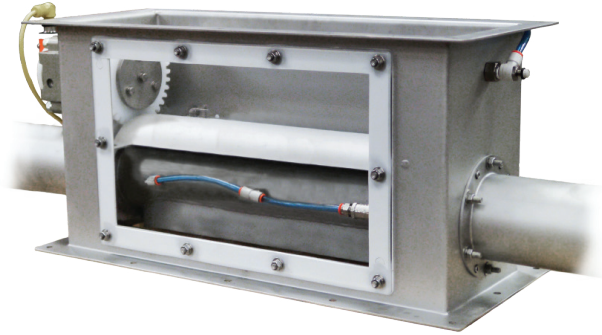

### 180° TURNAROUND

### PRODUCT INLET

With optional flow baffle

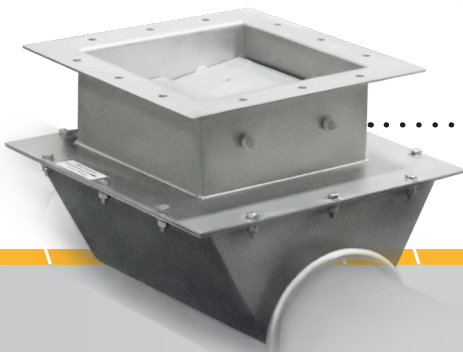

### CONNECTION LINK

All Nylock hardware with integrated polyurethane wiper disc and UHMW wear plate





## PROTECT & CONVEY YOUR PET FOOD APPLICATIONS

- Sanitary, FDA-approved materials feature UHMW discs on stainless steel chain or ultra high-strength hardened alloy steel chain
- Customize your conveying capacities from 12,000 to 50,000 lbs/hr
- To handle pet food product over long distance runs, all chain has an ultimate tensile strength of over 16,000 lbs

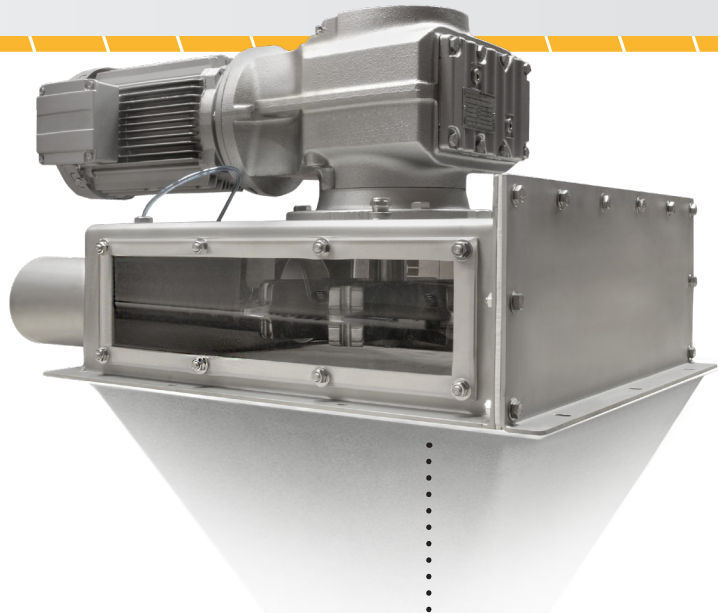

**180° DRIVE UNIT**

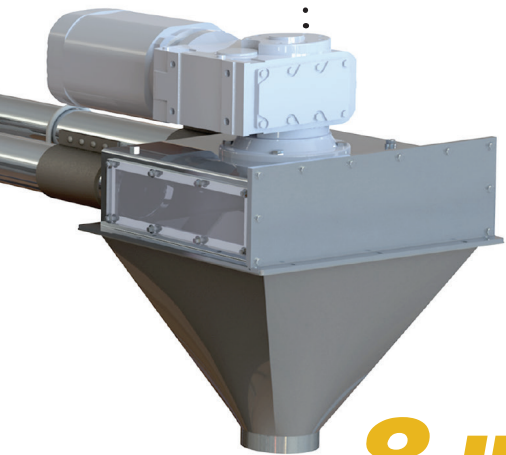

## CHOOSE YOUR CONVEYING CAPACITY

<b>8 IN.</b>	<b>6 IN.</b>	<b>5 IN.</b>	<b>4 IN.</b>	<b>3 IN.</b>
2,000 ft <sup>3</sup> /hr (56 m <sup>3</sup> /hr)	1,400 ft <sup>3</sup> /hr (40 m <sup>3</sup> /hr)	1,000 ft <sup>3</sup> /hr (28 m <sup>3</sup> /hr)	650 ft <sup>3</sup> /hr (18 m <sup>3</sup> /hr)	175 ft <sup>3</sup> /hr (8 m <sup>3</sup> /hr)



**RELIABLE**

# SUPERMAX

**CONNECTOR LINK SYSTEM**

**CHAIN-VEY®**

**A DIVISION OF MODERN PROCESS EQUIPMENT CORPORATION**

3125 SOUTH KOLIN AVENUE • CHICAGO, ILLINOIS 60623 U.S.A.

# CHAIN-VEY® VS. OTHER CONVEYING METHODS

CONVEYOR DESIGN FEATURES							
CONVEYOR METHODS	MAINTAINS PARTICLE DISTRIBUTION (INTEGRITY)	AIR / DUST TIGHT	CLEAN-IN-PLACE (CIP)	ENERGY EFFICIENT	EXTENDED LENGTH CAPABILITY	LOW / NO MAINTENANCE	MULTIPLE INLETS / DISCHARGES
<b>CHAIN-VEY®</b>	✓	✓	✓	✓	✓	✓	✓
<b>AUGER/ELEVATOR</b>						✓	
<b>BUCKET ELEVATOR</b>	✓			✓			✓
<b>DENSE PNEUMATIC</b>		✓			✓		✓
<b>DILUTE PNEUMATIC</b>		✓			✓		✓

## TYPICAL CHAIN-VEY® APPLICATIONS

### FOOD

Barley  
Bread Crumbs  
Brown Sugar  
Cereal  
Cheese Powders

Cocoa  
Coffee: Green  
Coffee: Ground  
Coffee: Roasted  
Coffee: Whole Bean

Cookie Crumbs  
Crackers  
Flour: Corn  
Flour: Wheat

Fruit: Dried  
Fruit: Frozen  
Hard Candy  
Hops  
Ingredients

Jelly Beans  
Krill Oil  
Malt / Meal  
Oats: Rolled  
Oats: Instant

Oats: Steel Cut  
Pepper  
Rice: Dried  
Rice: Puffed  
Snack Foods

Soluble Corn Fiber  
Soup Mix  
Spices  
Tea  
Vegetables: Frozen

Vitamins: Powdered  
Wheat

### BEANS / NUTS / SEEDS

Almonds  
Black Beans  
Cocoa Beans

Grains / Seeds  
Great Northern Beans  
Kidney Beans

Lentils  
Lima Beans  
Navy Beans

Oil Seeds  
Pecans  
Peanuts: Blanched

Peanuts: Roasted  
Pinto Beans  
Soy Beans

Walnuts

### PET FOOD

Chicken Meal  
Dry Food  
Fines / Add backs

Fish Food  
Fish Meal  
Horse Feed

Raw Ingredients  
Treats  
Whole Kibble

### CHEMICAL

Biomass (Torrefied)  
Calcium Carbonate  
Calcium Hydrate

Coke  
Detergent  
Feed Phosphate

Fertilizer  
Flake Resin  
Pesticide

Sodium Bicarbonate

### MINERAL

Activated Carbon  
Activated Coal Ash  
Alumina Hydrate

Ash  
Bentonite Clay  
Carbonate

Clay  
Coal  
Coal: Brown

Coal: Dry  
Graphite  
Limestone

Sintered Dust  
Talcum Powder

### OTHER

Latex  
Litter  
Pellets

Pigments  
Plastics  
Sawdust

Shredded Waste  
Tobacco  
Wax Flakes

Wood Chips

### DON'T SEE YOUR SPECIFIC APPLICATION?

Contact a MPE Sales Engineer in order to set up product feasibility testing at our Full Scale Chain-Vey Lab located in Chicago, IL, U.S.A.

## CHAIN-VEY®

A DIVISION OF MODERN PROCESS EQUIPMENT CORPORATION

3125 SOUTH KOLIN AVENUE • CHICAGO, ILLINOIS 60623 U.S.A.

WWW.CHAIN-VEY.COM • E: SOLUTIONS@CHAINVEY.COM • P: +1.773.254.3929 • F: +1.773.254.3935