

# MODEL GPX.WCI COFFEE GRINDER

The World's Only Industrial Water-Cooled Disc Coffee Grinder



The Model GPX.WCI is the ultimate disc-style coffee grinder. Not only does this model deliver superior grind quality for optimal brew performance, but it also keeps coffee 75% cooler than traditional disc-style grinders. Therefore, coffee volatiles and aroma are preserved and the true quality of one's coffee can be fully experienced.

- Low temperature preserves coffee volatiles
- Infinite grind adjustment
- Easy to clean and operate
- “Diamond hard” grinding discs

### ACCOMODATES ALL GRIND SIZES

|          |                 |
|----------|-----------------|
| ESPRESSO | FLAVORED COFFEE |
| DRIP     | VENDING         |
| REGULAR  | COARSE          |
|          | TURKISH         |



#### WATER-COOLED:

For a 75% decrease in coffee exit temperature



#### ECO-FRIENDLY:

Recycles its own water



MODERN PROCESS EQUIPMENT CORPORATION

THE WORLD'S LEADING MANUFACTURER OF COFFEE GRINDING EQUIPMENT

SERIES GPX.WCI

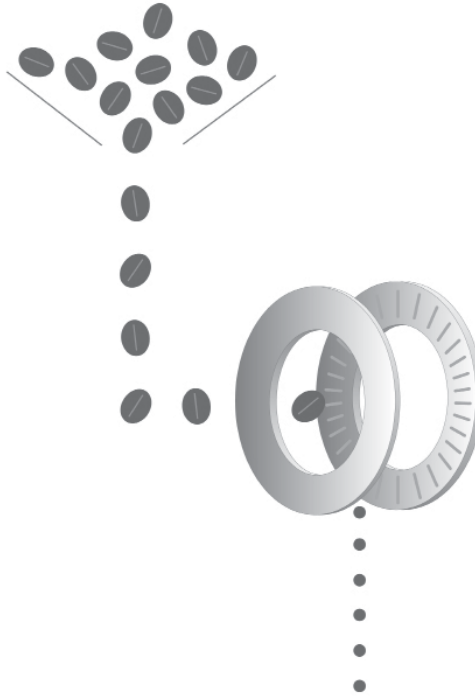

Precision  
Disc-Style  
Grinder



#### SPECIFICATIONS

- Disc Size:** 5.5 inches [140 mm] in diameter  
Grinding Discs can be re-sharpened
- Motor:** 3 HP [2.2 kW] / 1 or 3 phase / 50 or 60 Hz available
- Grind Range:** Turkish - Coarse [100-3,000 microns]
- Capacity:** 150-500 lbs/hr [68-225 kg/hr], Turkish to coarse respectively
- Drawing:** Available for download on website



#### FEATURES AND OPTIONS

- Self-contained water-cooling system.
- Designed for fast and easy cleanout – By simply removing three dial plate knobs, the entire grinding chamber can be removed and cleaned in minutes.
- Simple maintenance and operation – With few moving parts, maintenance and operation are easy.
- Engineered Discs – Grinding discs are engineered to deliver optimal grind uniformity and minimize heat.
- Sharp teeth and ultra-hard metal alloys ensure both performance and disc longevity. Economical re-sharpening also available.
- Hopper Sizes: 0.4 cu-ft (8 lb, standard) or 1.5 cu-ft (25 lb, optional)
- Bag holder tray (standard) or larger tote container (optional) for ground product collection.
- Hopper grate magnet (optional)



**MODERN PROCESS EQUIPMENT CORPORATION**

[mpechicago.com](http://mpechicago.com)  
[solution@mpechicago.com](mailto:solution@mpechicago.com)

3125 South Kolin Avenue  
Chicago, Illinois 60623  
U.S.A.

P +1 773 254 3929  
F +1 773 254 3935

# FLOOR MODEL

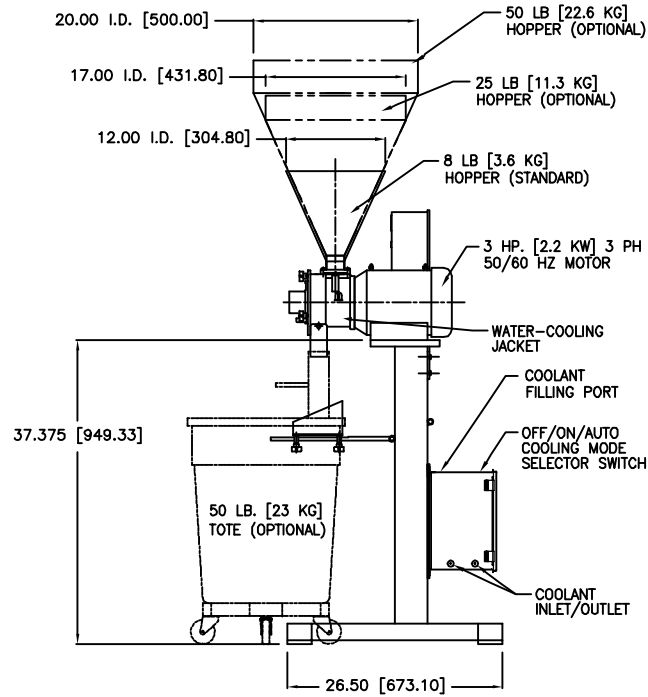
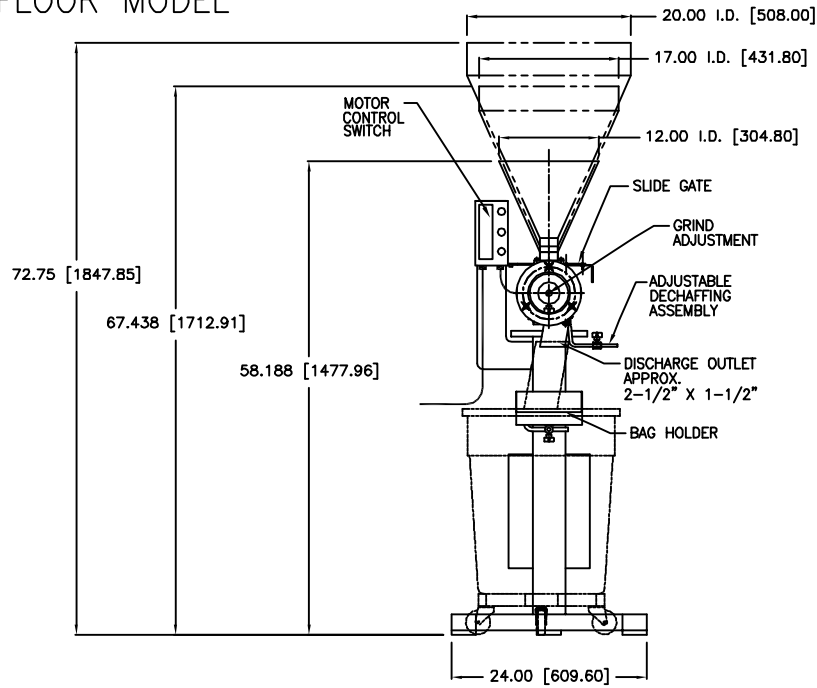

# BENCH MODEL

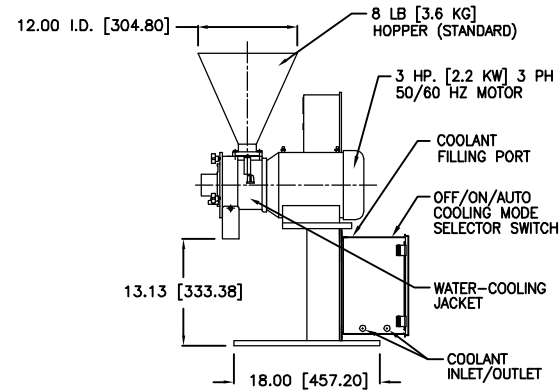
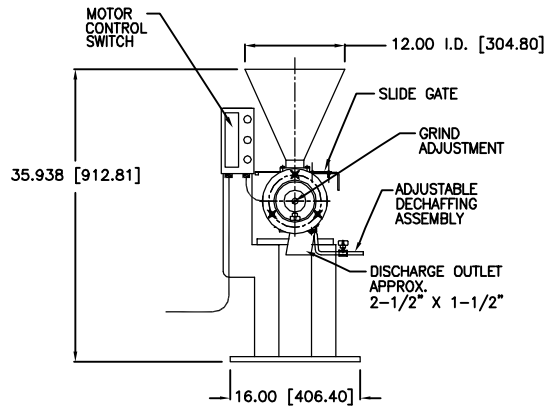

## NOTES:

1. DIMENSIONS WILL BE INDICATED AS FOLLOWED, 1 [25.4]

ENGLISH (IN) — METRIC (MM)

| GPX.WCI Specifications |  |
|------------------------|--|
| Motor:                 | Heavy Duty (3) Three HP TEFC 3 Phase 60 HZ 230/460 VAC (1750 RPM) ( Single Phase, 50 HZ, And Special Voltages Available) |
| Shipping Weight:       | 230 LBS (104 KGS)  |

| REV. | CHANGE | DATE | BY | MATERIAL | USED ON UNIT | <b>MODERN PROCESS EQUIPMENT, Inc.</b><br><small>3225 South Main Avenue, Chicago, Illinois 60628</small> | DRAWN   | RR   | SCALE  |
|------|--------|------|----|----------|--------------|---|---------|------|--------|
|      |        |      |    |          | MPE          |   |         | DATE | 1/6/09 |
|      |        |      |    |          |              | NAME OF PART  |         |      |        |
|      |        |      |    |          |              | MODEL   | GPX.WCI |      |        |
|      |        |      |    |          |              | Coffee Grinder  |         |      |        |
|      |        |      |    |          |              | PART NO.  | SG-7609 |      | C      |